



HANDLING AND STORAGE OF GYPSUM PANEL PRODUCTS: A GUIDE FOR DISTRIBUTORS, RETAILERS, AND CONTRACTORS (GA-801-07)

This guide was developed by the Gypsum Association to help train employees of distributors, lumber yards, home centers, drywall contractors and others who may handle gypsum panel products. Understanding and following the recommendations in this guide will help minimize damage to gypsum panel products during handling, shipment, and storage so they reach their destination in good condition for the final user.

Workers handling gypsum panel products shall follow strict work and safety rules, and procedures to protect their own health and safety and the well-being of others in the work area. Being aware of proper handling techniques helps reduce damage to property and equipment as well as the gypsum panel products being handled. The procedures in this guide shall be followed for the safe and protective handling, loading, shipment, and storage of gypsum panel products.

Local, state or federal laws or agency rules differing from the recommendations in this guide shall take precedence. The Gypsum Association and its member companies do not warrant or otherwise guarantee that following the procedures detailed in this guide will result in completely safe, effective, and satisfactory handling of gypsum panel products; no responsibility for accidents or goods damaged through handling may be assigned to the Association or its member companies.

The Gypsum Association disclaims any liability or responsibility for personal, property, or goods damage arising from recommended procedures described or shown in this guide.

CHARACTERISTICS OF GYPSUM PANEL PRODUCTS

Gypsum panel products is the general name for a family of sheet products consisting essentially of gypsum, a low density mineral found throughout the world. Gypsum board is manufactured with paper surfaces. Other gypsum panel products are either fiber reinforced or are manufactured with glass mat facers. Fiber reinforced gypsum panels are unfaced and have cellulose fiber in the gypsum core.

Gypsum panel products are flexible but will crack or break if bent beyond their stress limits. The edges and ends of the boards are susceptible to damage if dropped or struck by a hard object. Gypsum panel products may sag or warp if they become wet or are improperly supported while stored.

Gypsum panel products should bear the trademark or brand name, applicable ASTM standard or other designation, and the manufacturer, or supplier for whom the product is manufactured. Product identification markings may appear on the board surface, end bundling tape, or a separate sheet in bulk shipments.

The endtape of most gypsum board is printed with a Universal Product Code (UPC). While actual placement of the UPC on the endtape is at the discretion of each manufacturer, one UPC bar code identifies only one piece of gypsum board in the bundle.

Standards

Most gypsum panel products are defined by one of the following ASTM standards.

Gypsum Wallboard	ASTM C 1396/C 1396M
Gypsum Lath	ASTM C 1396/C 1396M
Gypsum Sheathing Board	ASTM C 1396/C 1396M
Gypsum Backing Board, Gypsum Coreboard, and Gypsum Shaftliner Board	ASTM C 1396/C 1396M
Gypsum Base for Veneer Plasters	ASTM C 1396/C 1396M
Water-Resistant Gypsum Backing Board	ASTM C 1396/C 1396M
Exterior Gypsum Soffit Board	ASTM C 1396/C 1396M
Predecorated Gypsum Board	ASTM C 1396/C 1396M
Gypsum Ceiling Board	ASTM C 1396/C 1396M
Fiber-Reinforced Gypsum Panels	ASTM C 1278/C 1278M
Glass Mat Gypsum Substrate for Use as Sheathing	ASTM C 1177/C 1177M
Glass Mat Water-Resistant Gypsum Backing Board	ASTM C 1178/C 1178M
Glass Mat Gypsum Panels	ASTM C 1658/C 1658M

Employees of distributors and retailers shall become familiar with the various types of gypsum panel products so that the correct board will be delivered to the customer.

HANDLING AND STORAGE

Special care shall be exercised when loading, securing shipments, warehousing, or otherwise handling gypsum panel products.

Safety Tips for Handling

Stacks of gypsum panel products are very heavy and can become unstable if proper stacking and handling procedures are not followed. Workers shall always be extremely careful when stacking or working in an area where gypsum panel products are stacked. For example, a 4 ft (1220 mm) wide by 12 ft (3660 mm) long by 1/2 in. (12.7 mm) thick gypsum board can weigh over 80 pounds (36 kg); this means a stack of only 25 of these boards weighs over a ton (900 kg). Heavy equipment is frequently used to move, stack, load, stock, or otherwise handle gypsum panel products. Only trained, qualified, and properly certified drivers may operate this equipment. Suitable safety measures shall always be followed when operating or working around these machines.

Procedures and techniques presented in this guide shall be followed to handle gypsum panel products properly. Workers who are inexperienced in using any of the tools or equipment in the procedures described, or are uncertain about the safety of these procedures for a particular activity or undertaking, shall consult with someone who is skilled or certified in this area of work before beginning. Seeking help from a more experienced worker or supervisor when uncertain about proper safety measures can safeguard against possible injury. Time, material, property, and equipment can

also be preserved. Safe work practices can make the job easier and more enjoyable as well as help prevent harmful and costly accidents. Remember and follow the safety tips below while handling gypsum panel products.

- Work in pairs whenever possible.
- Lift carefully with good techniques by using the legs, not the back.
- Stack gypsum panel products flat – not on edge or end.
- Wear a dust mask when conditions warrant.
- Ground electrical power tools properly.
- Select and use the correct tool for each job.
- Ensure that all tools are in good repair.
- Protect eyes with safety glasses or goggles when necessary.
- Proceed at a deliberate but steady pace.
- Always take precautions and time to make sure the work is done safely.
- Wear other personal protective devices and clothing such as a hard hat, gloves, safety shoes, etc.

Storage

Gypsum panel products shall be stored in a warehouse or other suitable structure where they will not be exposed to inclement weather or to temperatures that frequently exceed 125°F (52°C). Stacks of gypsum panel products shall be stored supported evenly on a firm, dry, level, and structurally sound floor. Stacks of gypsum panel products shall be limited to a maximum height of 17 feet (5 m). Gypsum panel products shall always be stored flat.

Gypsum panel products shall not be stored in areas of excessive humidity nor shall they be stored beneath overhead equipment which may have a tendency to drip grease, oil, or water. Gypsum panel products shall not be left in heavy traffic areas or where they can be damaged by lift trucks and other warehouse equipment, nor shall they be stored at aisle intersections. If panels are stored at aisle junctions because of absolute necessity, corner protectors constructed of sheet metal or similar suitable materials shall be used.

Exposure of gypsum panel products to rain and other high moisture levels may result in water stains, discoloration, mold, paper delamination, and sag. This sensitivity of most gypsum panel products to adverse moisture conditions requires that gypsum panel products NOT be stored outdoors without complete protection from the weather.

The plastic covering provided for product protection during shipment on rail flatcars or flatbed trucks is not suitable for storage of the gypsum panels and shall be removed upon arrival at the destination prior to warehouse storage. Failure to remove this plastic covering can result in damage to the gypsum panels due to moisture, condensation, wet product, and/or mold.

The Gypsum Association does NOT recommend outside storage of gypsum panel products.

Support Risers

Units of gypsum panel products shall be supported properly to minimize sagging. Precautions shall be taken in construction and placement of support members (known as risers or spacers).

Figure 1 shows risers that are easily and inexpensively constructed from strips of gypsum panels. If units of gypsum panel products shall be stored on a floor that may be subject to dampness, bottom risers shall be wood or plastic. All risers shall be of uniform height to ensure that the gypsum panel products are supported evenly. The most common size of risers is 3 in. (76 mm) wide by 3 in. (76 mm) high by the width of the gypsum panel product.

Figure 1 – Typical Gypsum Risers



Where permanent storage locations are designated for different lengths and types of board, appropriate signs shall be permanently posted. Additionally, the floor shall be marked to indicate where each length and type of gypsum panel products is to be stored. Riser locations may be painted on the floor to show proper riser spacing for the length of gypsum panel product in each space.

MINOR alterations in the location of risers are sometimes required to adapt to spacing of lift truck forks. When absolutely necessary, it is permissible to move risers a few inches in either direction as long as the number of risers is not reduced, the maximum distance between risers is not exceeded, and vertical riser alignment is maintained.

Since environmental concerns dealing with the reduction of the solid waste stream going to landfills make it increasingly difficult to dispose of worn-out gypsum risers. Distributors, retailers, and others who move gypsum may wish to construct permanent risers of wood or purchase plastic risers.

Preventing Sagging Gypsum Panel Products

One of the most common problems created by improper storage is sagging. Careful placement of risers as shown in Figure 2 will help minimize this problem. Figure 3 shows how sagging results when risers are placed improperly. Storage under these adverse conditions for an extended period may cause permanent distortion of the gypsum panel products, thereby rendering them useless and causing a loss to the owner.

Figure 2 – Correct Riser Alignment

Note that risers are aligned vertically so that loads are transferred directly to the floor.

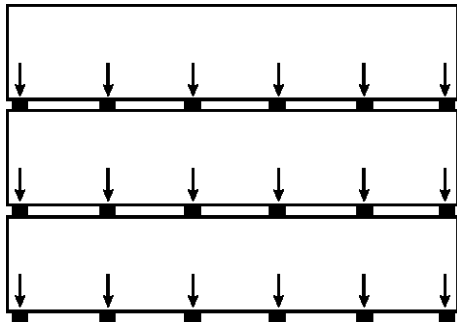
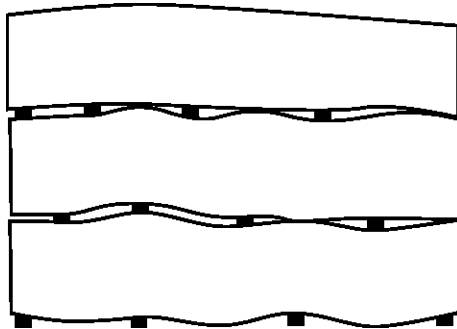

Figure 3 – Incorrect Riser Alignment

Note the sag resulting from misalignment of risers.



A good stock rotation plan and inventory control system will help avoid minor sagging problems. If minor sagging does occur, the gypsum panel products may be straightened by using the following method.

- Restack the panels and move the risers about four to six inches closer together than the recommended interval shown in Figure 4. Add evenly spaced risers as necessary to ensure that the entire stack is adequately supported. Risers shall be vertically aligned. The sagging will be reduced within several days.

The horizontal distance between risers shall not exceed 28 in. (700 mm). The recommended placement of risers for storage of various lengths of gypsum panel products is detailed in Figure 4. Long-term storage patterns require additional risers. Gypsum panel products should not be stored in high humidity areas; however, if such a storage area is used, additional risers shall be used.

Figure 4 – Suggested Placement of Risers for Storage of Gypsum Panel Products

Note: 14 ft (4270 mm) long panels shall be supported on not less than 6 risers and 16 ft (4880 mm) long panels shall be supported on not less than 7 risers.

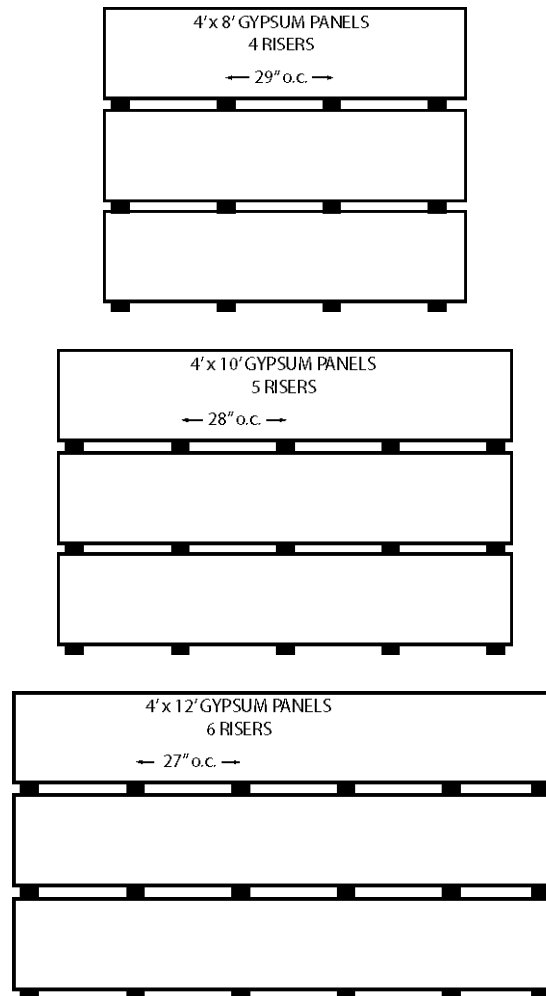

Manual Handling

Gypsum panel products shall always be handled carefully by two or more people. Gypsum panel products shall be delivered to the job site as near to the time they will be used as possible. Individuals delivering gypsum panel products to jobsites should ensure that they are carried, not dragged, to the place of storage or installation to prevent damage to finished edges. When panels are moved manually, the panels shall be supported by the edges and shall never be carried flat.

Mechanical Handling

Because of the bulky and heavy nature of gypsum panel products, they are almost always handled mechanically in warehouses, staging areas, storage, etc. Lift trucks are typically used to move stacks of gypsum panel products. Boom trucks are normally used to deliver gypsum panel products.

Lift truck drivers shall be trained and licensed to operate lift trucks in accordance with regulator requirements.

Although any lift truck in good condition can be used to move gypsum panel products, lift trucks with appropriate weight capacity ratings shall always be used to move units of board. A lift truck with a minimum 15,000 lb (6,800 kg) capacity is preferred for handling gypsum panel products.

Special forks are available to minimize the possibility of damage caused by a fork that contacts the bottom sheet of a stack of gypsum panel products. These forks feature rounded or beveled edges and a slightly exaggerated taper to the tip of the fork. Cushioning material applied to the load-face of the forks will minimize damage to the edge of the panels. Non-marking rubber or polyethylene backing pads installed on the back of the forks are recommended to absorb the impact between the fork uprights and the load. Cushioning the load face will reduce the incidence of panel edges being crushed or marred by the fork uprights. Side shifting forks may be less likely to damage units of panels and help prevent shifting or “inter-leafing” during transit.

Fork spacing shall be adequate for the length of panel products being carried. If only one length of gypsum panel products is handled, lift trucks with nonadjustable forks may be suitable. However, for maximum flexibility in handling gypsum panel products of varying lengths, forks shall be mounted on carriages which permit operators to adjust the distance between forks. Fork spacing shall be about one half the length of the panels being handled so that a maximum of four feet of panel extends beyond the forks on either end. A carriage spread in the range of 46 to 84 inches (1170 – 2130 mm) is suitable for carrying the most common lengths of gypsum panel products.

Great care shall be exercised by the lift truck operator when moving units of gypsum panel products. Even with padded fork backs, the impact between a moving lift truck and a stack of gypsum panel products may damage the edges of the panels. Operators shall practice easing up to the stack to be lifted to avoid unduly bumping the stacks.

Units of gypsum panel products shall not be divided by lift truck forks without the use of wedge blocks. These wedge-shaped blocks of wood or plastic are used to separate units of gypsum panel products without damaging the panels.

Gypsum panel products shall always be handled so the forks never come in contact with the finished surface (face) of the panels. Forks scraping across the face of gypsum panel products can damage the face.

End-strapping helps prevent excessive flexing of long lengths of gypsum panel products that could result in cracking or breaking. End-strapping shall not be removed until the panels are placed at the work site or are ready for stocking manually.

Use of Wedges

Fork lift operators can load orders alone if necessary by using a wooden or plastic wedge as shown in Figure 5. Two or three persons may be needed to stage, load, and fill orders if wedges are not used. When wedges are used risers may be omitted between units of stacked board. Stacking is simplified and less waste is generated when risers/spacers are not used.

The typical plastic wedge is 24 in. (600 mm) long by 8 in. (200 mm) wide with a 3 in. (75 mm) thick butt and is used in the same manner as the wooden wedge. Plastic wedges may be preferable because of their low cost and light weight nature, plus they generally last longer.

Figure 5 – Typical Wedge Block

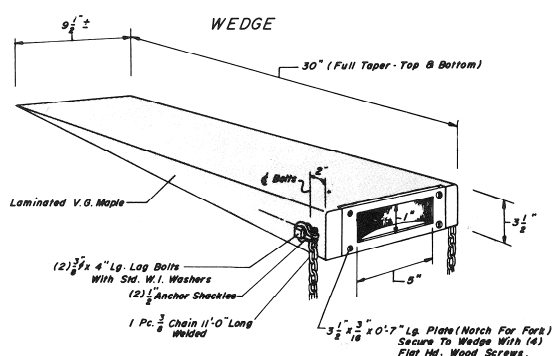

A concave metal cap may be attached to the butt end of the wedges in order to prolong their life and for easier insertion of the forks between the boards. To make removal of the wedge easier when gypsum board is stacked without risers, a hole may be drilled through the side of the wedge near the butt for attachment of a rope.

Paste wax applied to the wedge will provide a slippery surface for easier handling. Care shall be taken to prevent damage to the thin tip of the wedge. If damaged, the tip shall be ground to a new smooth edge.

Stocking Gypsum Panel Products on Job Sites

Gypsum panel products are heavy, awkward to handle, and come in a variety of lengths, thicknesses and types. If the customer's personnel assist with unloading and stocking, be sure the unloading supervisor makes them aware of, and that they follow, safety precautions.

Delivering a large quantity of gypsum panel products to a job site also requires special equipment, such as a boom truck specifically designed to expedite the unloading process. Only trained and qualified operators shall be permitted to operate the boom during the off-loading process. The operator shall be extremely careful with the boom to ensure that it does not come in contact with electrical or other utility lines or otherwise inflict damage in the area.

Regular flat-bed trucks with hydraulic lift-arms are frequently used to stock smaller jobs, such as residential structures. Drivers of gypsum panel products delivery trucks, especially to residential areas, shall exercise caution to ensure that property, such as septic systems, lawns and landscaping is not damaged. Damage to these types of properties may also result in damage to the truck and

expenses for the distributor/retailer. Drivers shall always carefully survey the unloading area to be sure that it is safe to drive into and use mechanical unloading devices.

Everyone shall always be aware of and observe the following when stocking gypsum panel products on job sites.

Gypsum panel products shall be delivered as near to the time that they will be used as possible, especially in commercial construction, since the structure or building may be left open to the elements and the board exposed to the weather if stocked prematurely.

Gypsum panel products delivered to a job site shall be placed under cover immediately and not exposed to outside elements such as rain, snow, or other high moisture conditions.

Construction sites can be dangerous places for visitors and others who are unfamiliar with the hazards inherent to construction and the safety precautions observed by professional construction workers. The safest way to store gypsum panel products on a jobsite is to stack them flat on risers that are placed on a solid surface. Storing gypsum panel products on edge leaning against wall framing can pose a serious hazard. Panels stacked on edge can easily become unstable, and the entire stack can accidentally topple or slip, which in turn can result in serious injury or even death.

- Panel products placed on a job site shall be separated by:
 - Type (Place the type of panel products near areas where it will be installed, e.g., type X, regular, moisture-resistant, etc. This system of placement reduces the chance that the wrong type of panel product will be installed and applicators/hangers will have easy access to the stocked gypsum panel products.)
 - Size (Do not place longer-length panel products on top of shorter lengths.)
- Gypsum panel products shall be stocked out of the way of construction traffic.
- Special care shall be taken to ensure that the gypsum panel products do not damage the exposed studs, windows, door frames, etc.
- Gypsum panel products shall be stocked so as not to hinder the work of construction tradesmen, such as electricians and plumbers.
- Gypsum panel products stocked on a job site shall never have any other materials stored or stacked on top of them.
- Gypsum panel products shall be stocked so their weight is evenly distributed and the floor is not overloaded.
- Gypsum panel products shall not be stacked high enough to pose a danger from toppling.
- Gypsum panel products stocked in unenclosed buildings shall be placed far enough inside so that they are not exposed to inclement weather, such as blowing rain or snow.
- Special care is necessary when stocking upper floors of open buildings during periods of high winds.

LOADING GYPSUM PANEL PRODUCTS

Gypsum panel products are shipped by rail cars and trucks. The loading procedures described below shall be followed.

Open Top Rail Flatcars

Distributors or reloaders may have occasion to load gypsum panel products onto rail cars. All rail cars shall be thoroughly inspected by the shipper for defects before loading. Special attention shall be given to the alignment of bulkheads, the condition of floors, and the soundness of bulkhead welds. If the bulkhead is broken at the base or out of plumb, the car shall be rejected. Minor misalignment may be corrected by nailing gypsum panel product dunnage to the bulkhead. Such dunnage shall not exceed 24 in. (600 mm) in width.

Floor and bulkhead surfaces shall be structurally sound and free from holes. If the floor is in disrepair, the car shall be returned to the carrier for repairs.

Strict general and specific rules governing the loading of gypsum panel products on rail cars are published by the railroads. Failure by a shipper to comply with the rules may result in forfeiture of all claim rights in case of damage. Additionally, legal liability issues may arise for the shipper in case of a transit accident.

The Association of American Railroads (AAR) updates its rail loading rules annually. It is the shipper's responsibility to conform to the most current rules. Copies of the rules are available from AAR, 50 F Street, N.W., Washington, DC 20001; 202-639-2100; <http://www.aar.org>.

Railroads disclaim liability for damage due to moisture. Extreme care shall be taken to adequately cover loads on flatcars. Sheathing paper can be used atop loads beneath a one-piece polyethylene or similar covering material. End caps shall be applied carefully. All tears or other damage shall be patched or otherwise fully repaired.

Flatbed Trucks

Each state, as well as the U. S. Department of Transportation (DOT) for interstate commerce, has well-defined laws, rules, and regulations regarding transport by truck. Equipment and personnel shall meet all applicable regulations.

The motor carrier, or driver, is responsible for the quality and safety of tie-downs used to secure the load. A variety of tie-down types is available, such as polyester webbing, steel strapping, chains and rope. Webbing may be preferable because it is unaffected by moisture, normally it does not stain, and it provides uniform tension each time a load is secured. The tie-downs shall be located as directly as possible over the vertical risers in the gypsum panel product load. Corner protectors shall be used so that the top pieces of gypsum panel products are not damaged.

The cover used over loads of gypsum panel products on flatbed trucks or trailers shall be completely waterproof and weather tight. If two-piece fitted covers are used, the front cover shall overlap the rear section by a minimum of two feet to avoid leaks during transit.

Drivers shall stop periodically to inspect the condition of the load and the tie-downs, depending upon travel distance and road conditions.

All drivers handling gypsum panel products shall be instructed in proper handling and delivery techniques. The following guidelines can be used by distributors or retailers in their driver training programs. This set of guidelines may be posted on employee bulletin boards and furnished to each individual driver.

Guidelines for Carriers and Drivers

- Before loading a truck or trailer, check to ensure that it is clean and free of any objects that might damage the gypsum panel products. Floors shall be in good condition to keep materials dry and free from damage due to wet roads. Floor or other damage shall be reported to management promptly.
- Ensure that the load will ride securely and safely and that all regulatory requirements are observed.
- Check the load quantity before leaving the distribution center or yard; the driver is responsible for any shortage or damage.
- Check the condition of the cover to ensure that the load will be adequately protected. (The load cover shall completely cover the load to the vehicle's floor.)
- Be sure that the load is securely anchored to the trailer to prevent loss or damage in transit. Make periodic inspections of the load while en route to the destination, depending on distance and road conditions.
- Make a notation on all copies of the billing of the exact nature and extent of any shortage or damage. Sign notation as driver. Be sure customer also signs all copies. Material shall not be returned to the distribution center or yard without prior approval.
- Monitor the unloading since material damaged by customer during unloading is the customer's responsibility. Do not accept such material for return. Do not indicate such damage on billing copies or delivery receipt. Make a separate report of this damage to the office. Do not accept material from previous shipment(s) for return unless driver's supervisor gives authorization.

Gypsum panel products require special handling because of the potential for damage to the material and safety considerations for workers. By following proper handling techniques, neither the board will be damaged nor the workers injured.